

(No Model.)

12 Sheets—Sheet 2.

L. BOLLMANN.
SEWING MACHINE.

No. 260,645.

Patented July 4, 1882.

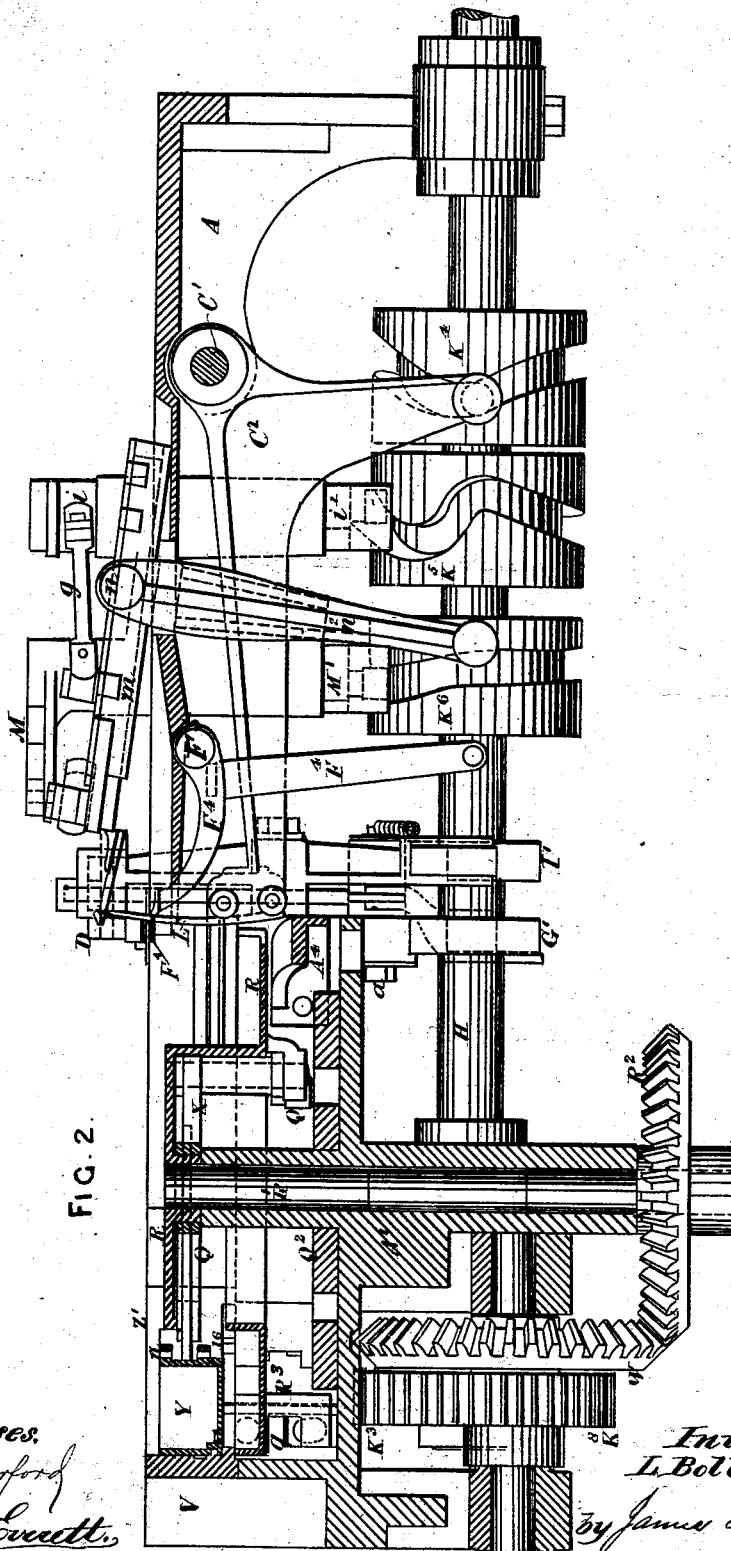

FIG. 2.

Witnesses:
J. A. Rutherford
Robert Everett

Inventor:
L. Bollmann.

by James S. Norris
Atty

(No Model.)

12 Sheets—Sheet 3.

L. BOLLMANN.
SEWING MACHINE.

No. 260,645.

Patented July 4, 1882.

Fig. 3

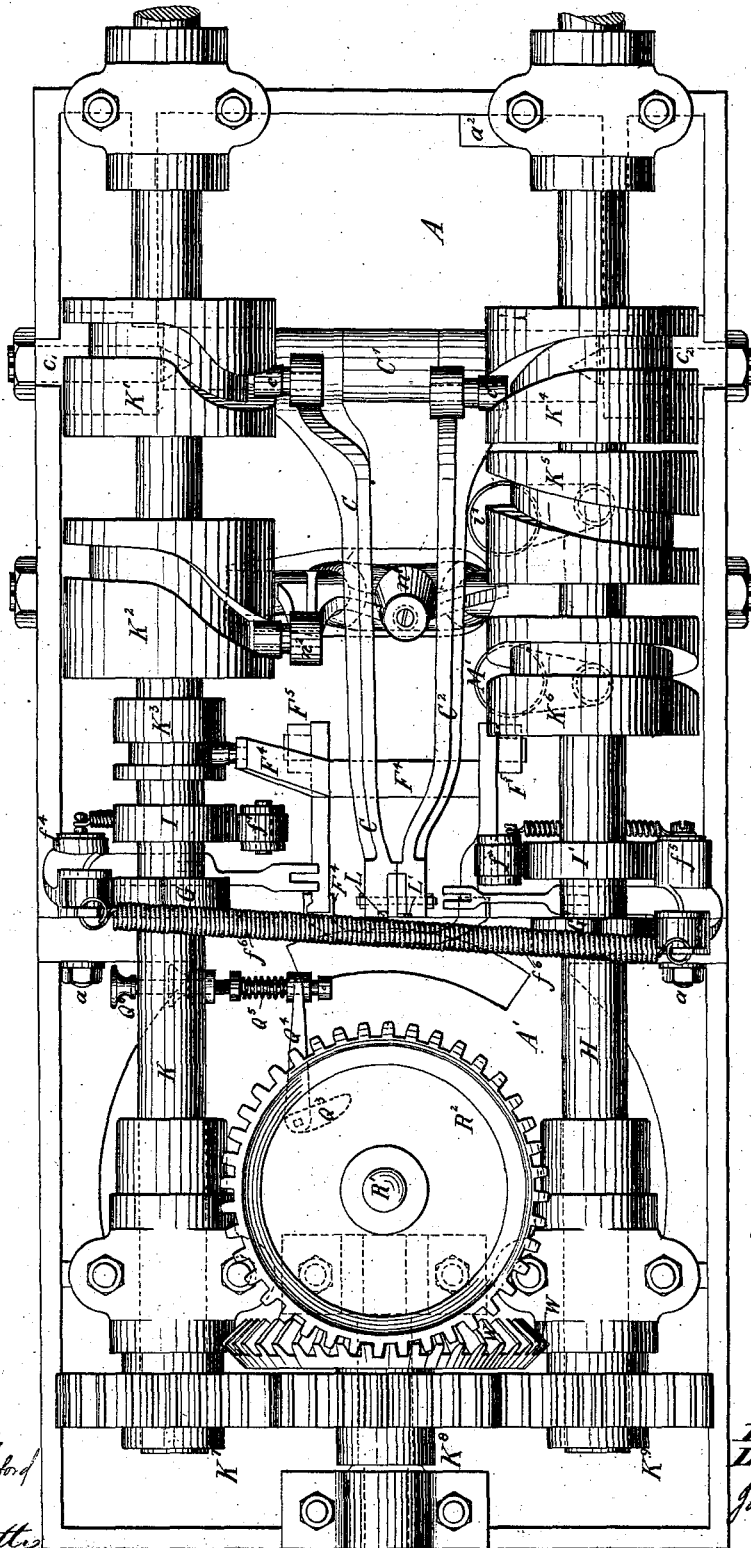

Witnesses,
J. A. Kutherford
Robert Emmett

Inventor
L. Bollmann.
Geo. L. Norris
Atty

(No Model.)

12 Sheets—Sheet 4.

L. BOLLMANN.
SEWING MACHINE.

No. 260,645.

Patented July 4, 1882.

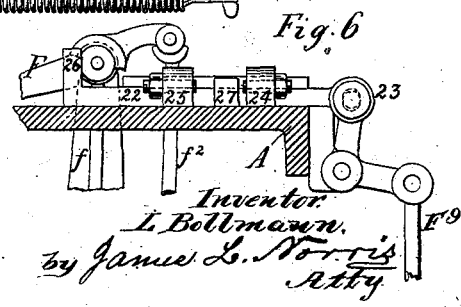
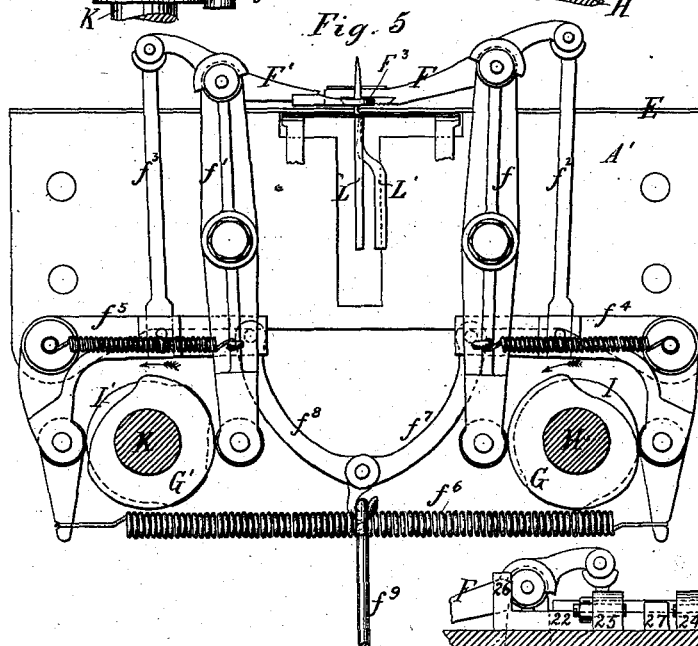
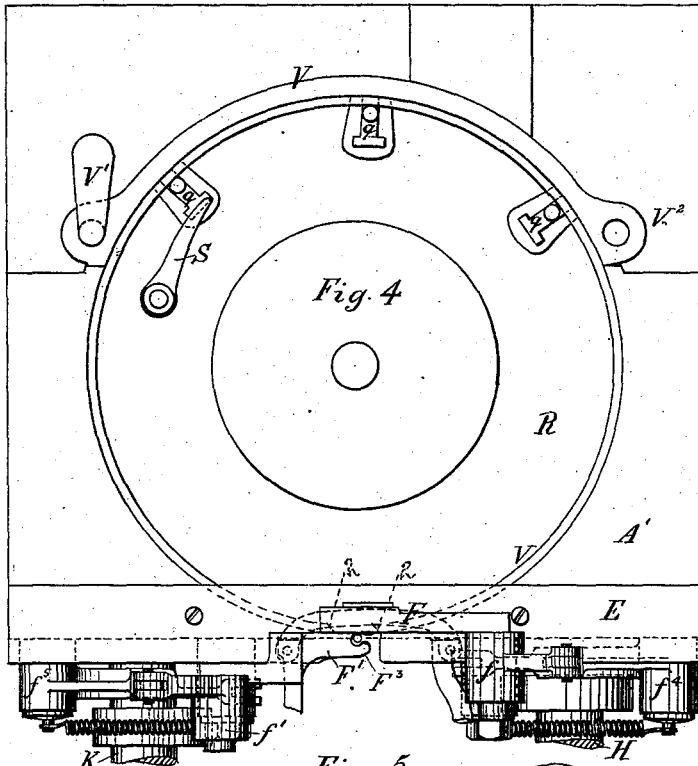

Witnesses.
J. A. Rutherford
Robert Covatt

Inventor
L. Bollmann.
 by *James L. Norris*
 Atty.

L. BOLLMANN.
SEWING MACHINE.

No. 260,645.

Patented July 4, 1882.

FIG. 7.

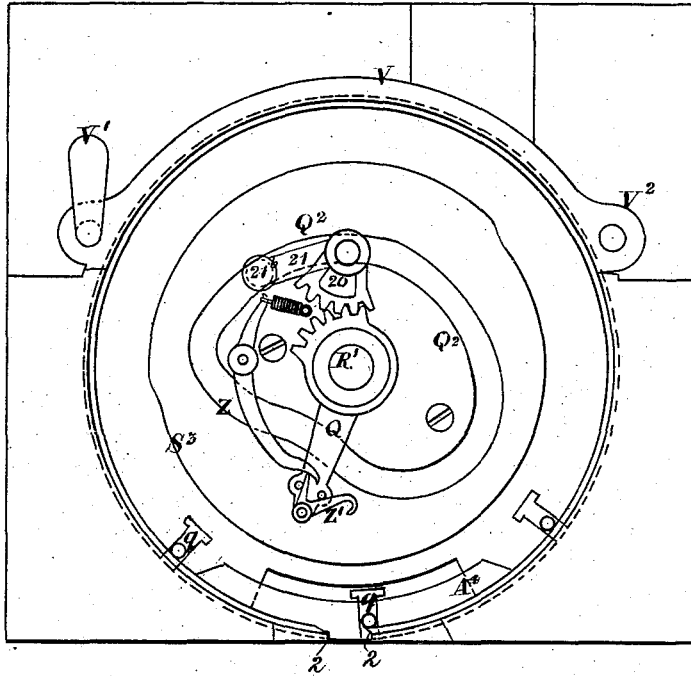

FIG. 8.

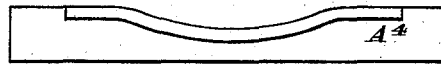
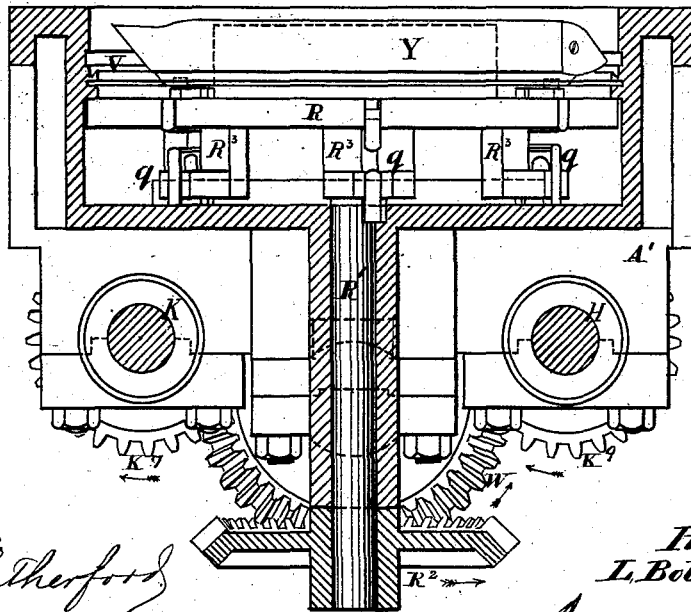

FIG. 9.



Witnesses
J. A. Rutherford
Robert Everett

Inventor:
L. Bollmann.
 by *James L. Norris,*
Atty.

L. BOLLMANN.
SEWING MACHINE.

No. 260,645.

Patented July 4, 1882.

FIG. 10.

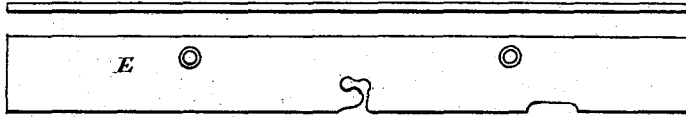

FIG. 11.

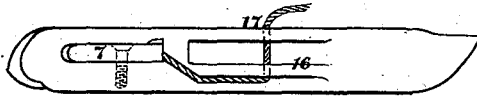

FIG. 12.

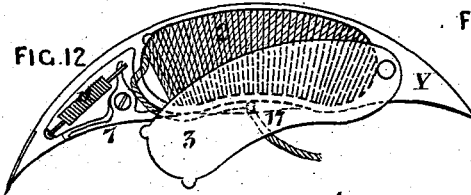

FIG. 15.

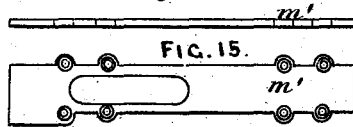

FIG. 17.



FIG. 19.



FIG. 20.

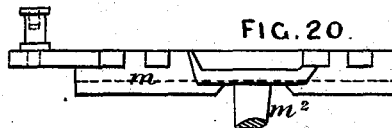

FIG. 22.



FIG. 23.

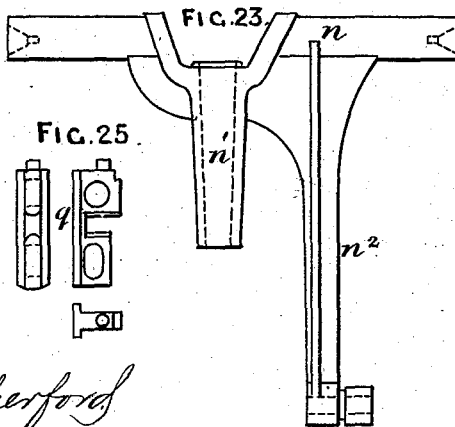

FIG. 25.

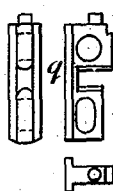

FIG. 14.

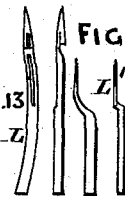

FIG. 16.

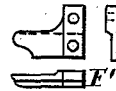

FIG. 18.



FIG. 21.

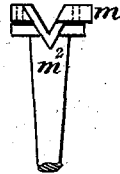
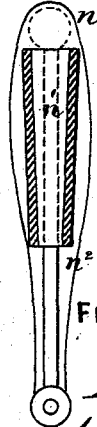

FIG. 24.



Witnesses,
J. A. Rutherford
Robert Everett

Inventor,
L. Bollmann.
by *James L. Morris*
Att'y

(No Model.)

12 Sheets—Sheet 7.

L. BOLLMANN.
SEWING MACHINE.

No. 260,645.

Patented July 4, 1882.

Fig. 31

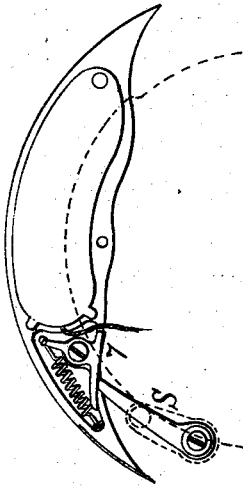

Fig. 30

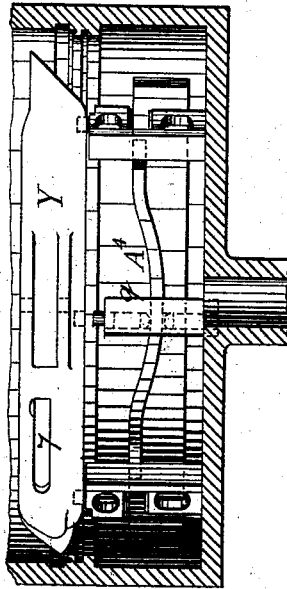

Fig. 32

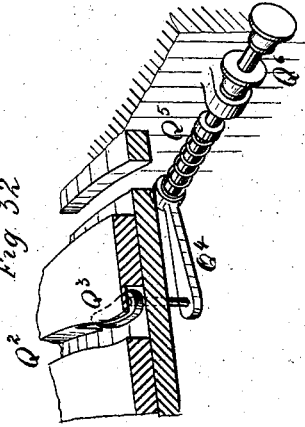

Fig. 26

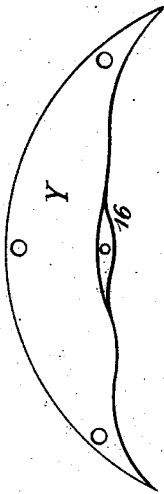

Fig. 27

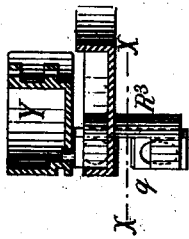

Fig. 28

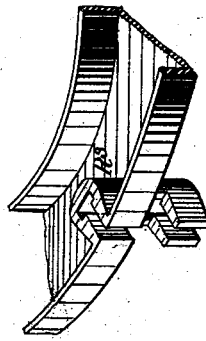

Fig. 29



Witnesses.

J. A. Rutherford
Robert Connett.

Inventor.

L. Bollmann.

By James L. Norris.

Atty.

(No Model.)

12 Sheets—Sheet 8.

L. BOLLMANN.

SEWING MACHINE.

No. 260,645.

Patented July 4, 1882.

Fig. 34

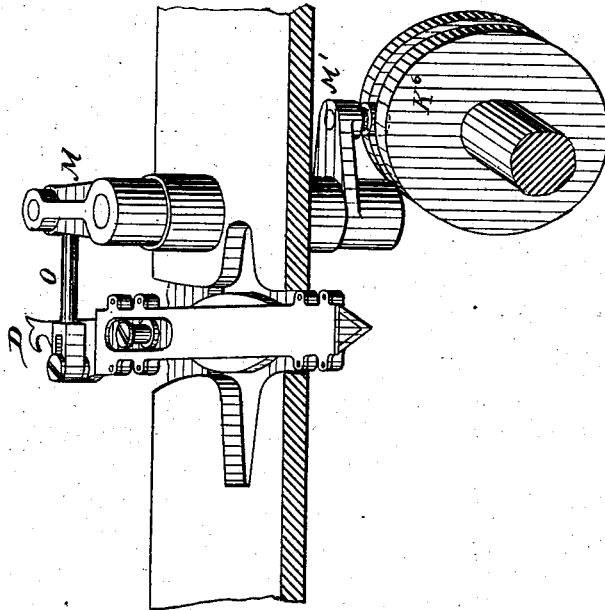
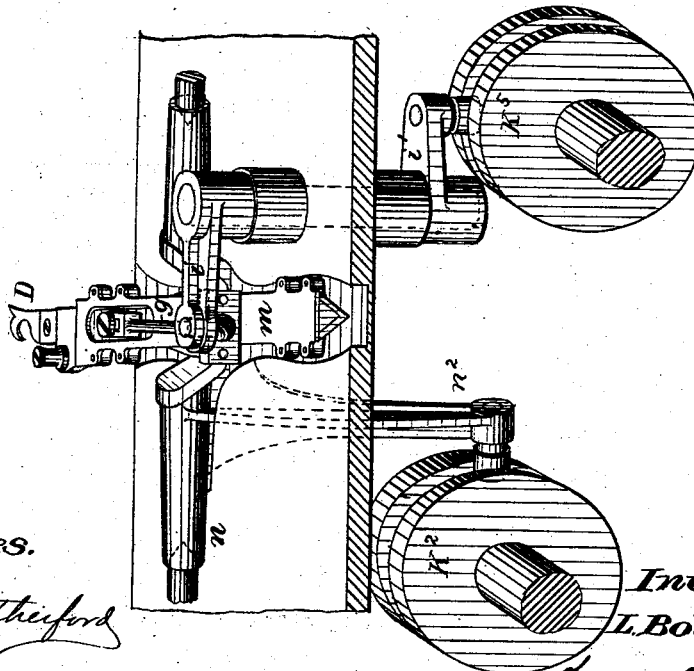

Fig. 35



Witnesses.

J. A. Rutherford
Robert Everett,

Inventor.

L. Bollmann.

By *James L. Norris,*
Atty

L. BOLLMANN.
SEWING MACHINE.

No. 260,645.

Patented July 4, 1882.

Fig. 35

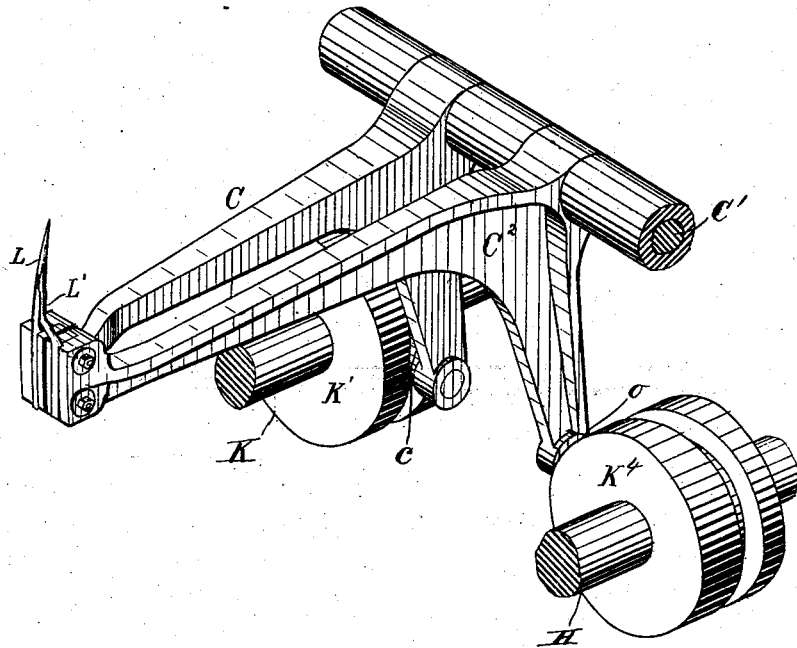
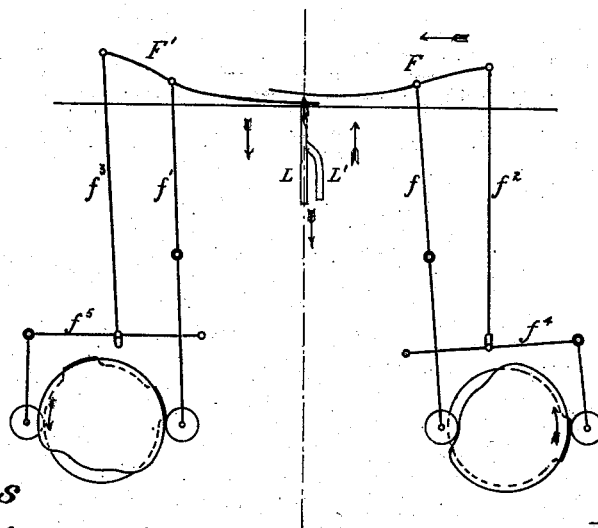

Fig. 40



Witnesses

J. A. Rutherford
Robert Everett

Inventor

L. Bollmann.

By *James L. Norris,*
Atty.

L. BOLLMANN.
SEWING MACHINE.

No. 260,645.

Patented July 4, 1882.

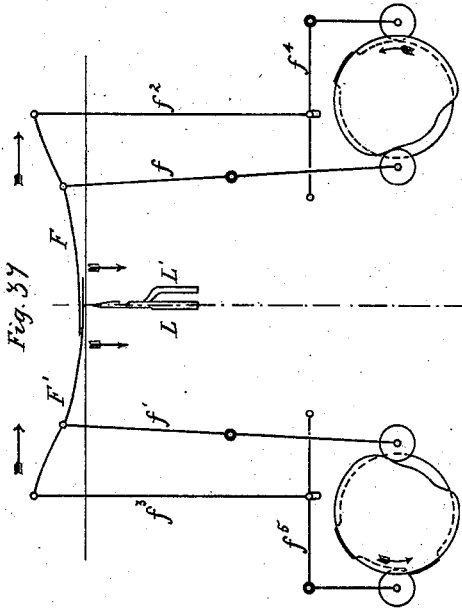

Fig. 39

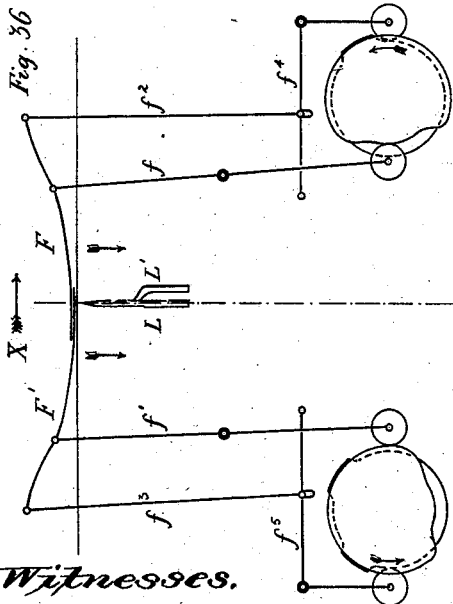
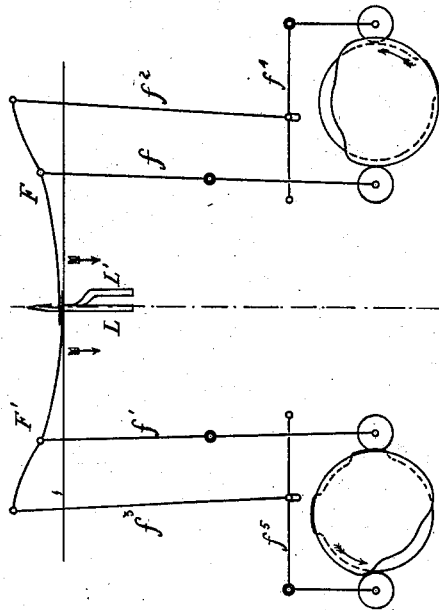
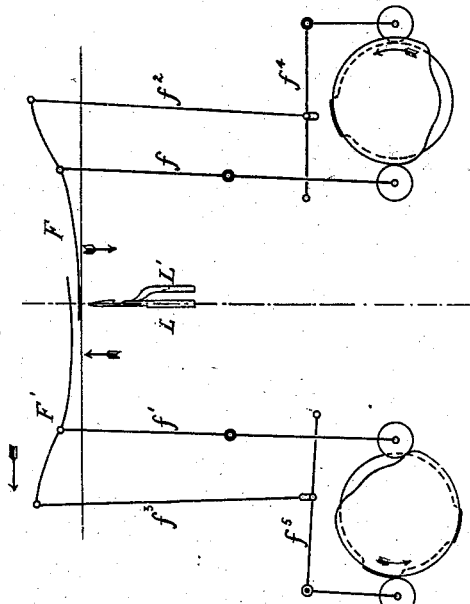

Fig. 38



Witnesses.

J. A. Rutherford
Robert Everett

Inventor.
L. Bollmann.
By James L. Norris.
Atty.

(No Model.)

12 Sheets—Sheet 11.

L. BOLLMANN.
SEWING MACHINE.

No. 260,645.

Patented July 4, 1882.

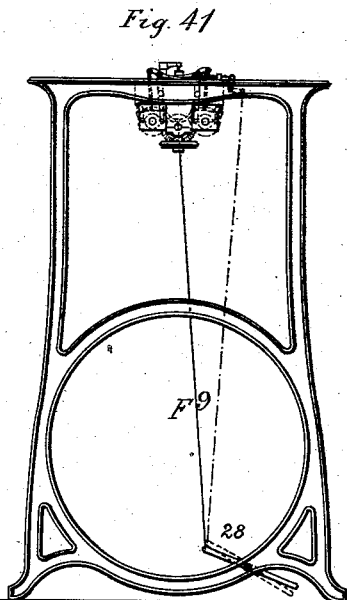
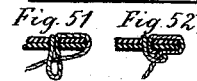
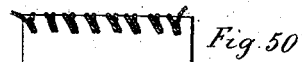
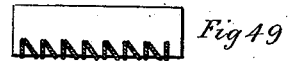
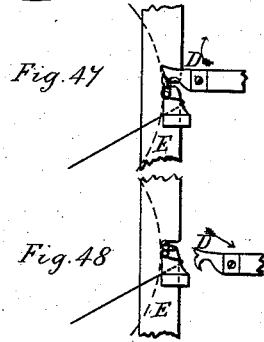
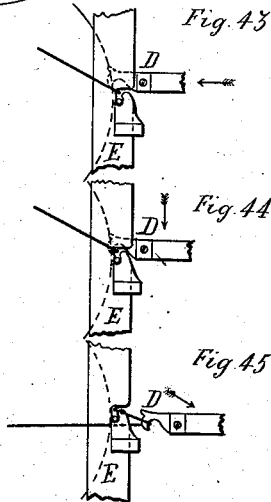
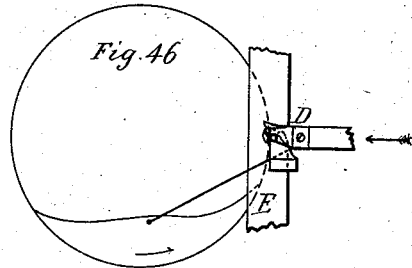
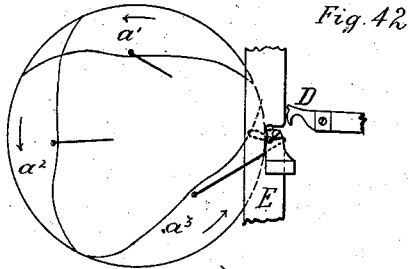

Witnesses.
J. A. Rutherford
Robert Everett

Inventor.
L. Bollmann.
 By *James L. Norris*
J. L. N.

(No Model.)

L. BOLLMANN.
SEWING MACHINE.

12 Sheets—Sheet 12.

No. 260,645.

Patented July 4, 1882.

Fig. 53

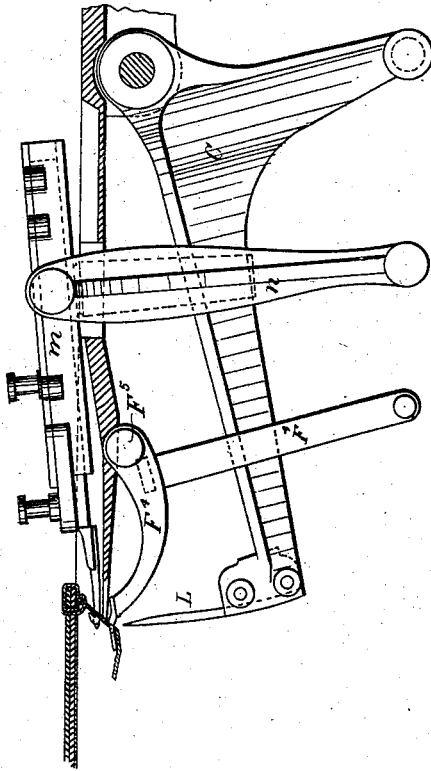

Witnesses.

J. A. Rutherford
Robert Everett

Inventor.
L. Bollmann.

By James L. Norris.

Atty.

UNITED STATES PATENT OFFICE.

LOUIS BOLLMANN, OF PENZING, NEAR VIENNA, AUSTRIA-HUNGARY, AS-SIGNOR TO GEORGE WOOD RICHARDSON AND ALEXANDER STORER, BOTH OF LINWOOD, NEAR PAISLEY, GREAT BRITAIN.

SEWING-MACHINE.

SPECIFICATION forming part of Letters Patent No. 260,645, dated July 4, 1882.

Application filed March 11, 1881. (No model.) Patented in Germany August 13, 1879; in France August 13, 1879; in Belgium August 19, 1879; in England December 14, 1880, No. 5,252; in Austria April 8, 1881, and in India August 26, 1881.

To all whom it may concern:

Be it known that I, LOUIS BOLLMANN, a citizen of the United States, residing at Penzing, near Vienna, Austria-Hungary, have invented an Improved Construction of Sewing-Machines, (for which Letters Patent of Great Britain have been granted to Alexander Storer, bearing date 14th December, 1880, No. 5,252, a communication to him by Louis Bollmann, Jr., and Josef Bollmann,) of which the following is a specification.

My invention relates to an improved construction of that description of sewing-machines for overhead sewing for which Letters Patent of the United States were issued to J. Bollmann and L. Bollmann on the 18th day of October, 1881, No. 248,552, wherein such overhead sewing was effected by the combined action of a revolving shuttle, a reciprocating needle, and a reciprocating hook. According to my present invention, I construct such machines as shown on the accompanying drawings, in which—

Figure 1 shows a plan partly in section; Fig. 2, a longitudinal section on line X X, Fig. 1; Fig. 3, an under side plan; Fig. 4, a plan of the shuttle-race and feed mechanism; Fig. 5, a cross-section on line Y Y, Fig. 1, showing the feed mechanism; Fig. 6, a detail of the feed-regulator; Fig. 7, a plan of the shuttle-race, with mechanism for regulating the stitch and taking up slack; Fig. 8, an elevation of the curved bar for withdrawing the pins driving the shuttle; Fig. 9, a cross-section on line Z Z, Fig. 1. Figs. 10 to 53 show detached details of the needle-plate, shuttle, needle, hook and its gear, and pins driving the shuttle, all of which detail figures will be hereinafter explained.

The framing A A' carries two parallel camshafts, H K, the cams on which actuate the various mechanisms to be presently described. Either shaft is driven from any convenient motor or by treadle, and drives the other through the spur-wheels K⁷ K⁹ and intermediate wheel, K⁸, whose shaft drives a bevel-pinion, R², on the shaft R' of the shuttle-driver

through a bevel-wheel, W. The shuttle Y is driven by vertical pins *g*, carried by the shuttle-driver R, and entering holes in the under side of the shuttle in a manner similar to that described in the before-mentioned previous application. The pins *g* have, however, in this case downward extensions working in guides R³. As the pins in their revolution with the shuttle-driver are brought to the part beneath the needle their notches engage with the curved bar A⁴, the downward curvature of which causes the pins to be consecutively drawn downward out of gear with the shuttle, so as to allow the loop of thread to pass over it at that point. These parts are more clearly shown in Figs. 25, 26, 27, 28, 29, and 30, Fig. 25 showing a front and side view and plan of the pin; Fig. 26, an under side view of the shuttle; Fig. 27, a section through the shuttle-race and shuttle, showing a side view of the guides R; Fig. 28, a perspective view of the guides; Fig. 29, a section on the line *xx* of Fig. 27; Fig. 30, a section of the shuttle-rack, with the shuttle in elevation, driving-pins, and curved bar A⁴, the middle driving-pin being drawn downward by the curvature of said bar to allow of the passage of the loop of thread over the shuttle.

The shuttle Y has an oblong cavity, 2, closed by a pivoted cover, 3, in which cavity is placed the thread in the form of a cop. The end of the thread is led from the interior of the cop through a hole in the end of the cavity, whence it passes to outer flanges, 16 and 17, on the inner face of the shuttle, through holes in which it is threaded, as indicated at Figs. 11 and 12. On its passage to these holes the thread is pressed upon by a lever, 7, acted upon by a spring, 11, of sufficient force to prevent the delivery of the thread from the cop.

The lever 7 has a tail which is acted upon by a finger, S, on a spindle carried by the shuttle-driver, as more clearly shown in Fig. 31, which shows a plan of the shuttle with the lever 7 pressed upon by the finger S to release the thread from its nip, said finger having at its lower end an arm provided with a roller that bears against a fixed cam, S², Fig. 1, on the

bottom of the shuttle-race. This cam is so formed that when at a certain point of the revolution of the shuttle it is required to deliver the thread from its cop the arm is moved by the cam, so as to cause the finger S to press upon the tail of lever 7, against the action of spring 11, and so release the thread more or less from its nip, allowing it to pass out freely, or with only as much friction as is necessary to maintain the requisite tension. The portion of thread exposed between the flanges 16 and 17 is laid hold of and drawn out into a loop when the slack requires to be taken up and the stitch tightened, this operation being performed by a hook, Z', as follows: The hook is pivoted to an arm, Q, mounted loosely with its boss on the spindle R' of the shuttle-driver, and having teeth which gear with a segment, 20. This segment is on an axis carried by the shuttle-driver, and has an arm, 21, at its lower end acted on by a spring, 21^a, and whose roller 21^b runs in a fixed cam-groove, Q², in the bottom of the shuttle-race. This cam-groove is so formed that as the driver rotates, the segment 20 is caused at one time to turn the arm Q somewhat in one direction and then in the contrary direction. The hook Z' has a tail, against the end of which bears the curved end of a lever, Z, carried by the shuttle-driver, and acted on by a spring, as shown, so as to maintain frictional contact between it and the tail of the hook. The effect of this arrangement will be that when by the one motion of the arm Q the hook Z' is advanced toward the part of the thread between 16 and 17, in order to seize it and draw it out into a loop, the friction between the hook's tail and the lever Z at the same time causes the hook to be turned forward on its pivot, so as to pass behind and seize the thread, while when the arm Q is moved in the contrary direction, in order to release the thread from the hook, the latter is by the above means caused to turn backward on its pivot, and thus to pass out of the loop of thread and recede sufficiently so as not to interfere with the loop through which the shuttle passes to form the stitch. Fig. 1 shows the position of the hook Z' just in the act of seizing the thread between 16 and 17 when the arm Q and hook are moving relatively to the shuttle in the direction of the arrow, and Fig. 7 shows the hook in the backward position. The tail of the hook plays between two stops on the arm Q, as shown, whereby the extent of its motion is limited.

In order to adapt the machine to sew heavier or lighter material, the cam-path Q², which imparts the above-described motion to the hook Z', is at that point where it has to effect the final tightening of the thread partly cut out, and a piece, Q³, Fig. 1, inserted, which piece is connected to an arm, Q⁴, Figs. 1 and 3, acted upon by a helical spring, Q⁵, the tension of which can be regulated by a screw, Q⁶, as shown, said parts being more clearly illustrated in Fig. 32, which shows a perspective view of the piece Q³, with its spring Q⁵ and

regulating-screw Q⁶, said screw being supported in a suitable eye or bearing on the machine-framing. Thus when, during its rotation, the roller of the arm 21 comes in contact with Q³, this, and consequently the arm, can yield more or less, according to the quantity of thread required for thick or thin material. Access is gained to the shuttle for introducing it into and removing it from its race by arranging part of the circular wall V of such race to open on a hinge, V², as a door, it being secured by a catch or bolt at V' when closed. The ring or circular wall V is cut away, as shown at Figs. 4 and 7, to form the points 2 2, for a purpose hereinafter explained.

The construction and action of the hook D, by means of which the thread is carried from the one side of the fabric to the other over its edge, are the same as in the Patent No. 248,552, hereinbefore referred to; but the arrangement of mechanism for imparting to it its several movements is modified as follows, for the purpose of working at greater speed: The hook D is secured to a prismatic bar, D', as shown detached in side view, end view, and plan at Figs. 17, 18, and 19, which bar slides to and fro in a carrier, *m*, (shown detached in side view, end view, and plan at Figs. 20, 21, and 22,) in which it is inclosed by a cover, *m'*. (Shown in edge view and plan at Fig. 15.) The requisite in-and-out motion is imparted to the hook-bar as the hook moves from above the needle-plate to below it, and conversely, as described below, by means of lever *i*, connected by rod *g* to a stud on the bar projecting through a slot in the cover *m'*. Lever *i* is fixed on an axis having at its lower end a second lever, *i'*, having a roller gearing with the cam K⁵ on shaft H, whereby the requisite to-and-fro motion is imparted to *i*. The carrier *m* has a pivot, *m*², fitting into a socket, *n'*, on a bar, *n*, (shown in front view and section at Figs. 23 and 24,) which is mounted with its ends on lathe-centers, and has an arm, *n*², extending downward and carrying a roller that takes in the groove of a cam, K², on shaft K, this cam being so formed as to rock the bar *n* on its centers, and thus impart an up-and-down motion to the carrier *m* and hook-bar D', a lateral to-and-fro motion being also imparted to the carrier *m* upon its pivot *m*² by means of a lever, M, Figs. 1 and 2, connected thereto by a rod, O, the axis of the lever M having at its lower end a second lever, M', Fig. 3, gearing with a roller in the groove of cam K⁶ on shaft H. These parts are more fully shown in Figs. 33 and 34, Fig. 33 being a perspective view of the hook-bar D', with its operating-levers *i* *i'* and K⁵, as also the arm *n*² and cam K² for imparting the rising-and-falling motion to the hook, and Fig. 34 being a perspective view of the levers M M' and cam K⁶ for imparting the lateral motion to the hook. By the above-described means the hook D has imparted to it its compound motion, consisting of an in-and-out, backward-and-forward, and an up-and-down movement, as described in the before-mentioned previous patent.

The hooked needle L, Fig. 13, with its slide L', Fig. 14, for closing the hook, while passing through the fabric, operates in the same manner as described in the patent before referred to; but instead of the slide being pivoted on the needle-arm and actuated by a spring and fixed stops it is mounted on a separate lever actuated by a separate cam.

C, Figs. 2 and 3, is the lever-arm of the needle, pivoted on shaft C' and gearing with its roller *c* in the groove of the cam K' on shaft K, and C² is the lever-arm of the slide L', also pivoted on shaft C' and gearing with its roller *c'* in the groove of cam K² on the shaft H, which cam is so formed as to impart the requisite motion to the slide relatively to the needle as to open and close its hook at the proper times. These parts are more clearly illustrated in Fig. 35, which shows a perspective view of the needle-arm C and slide-arm C² and their respective cams, the cam K' of the slide L' being so formed that when the needle L is passing down through the cloth with the loop of thread the slide moves upward relatively to the needle, so as to close the hook or open eye thereof, as shown in this figure and at Fig. 40, while when the needle-bar has passed down through the cloth the slide moves downward relatively to the needle, so as to open its eye, after which the slide moves, together with the needle, leaving the eye open, as shown at Figs. 36 to 39, until the needle again passes down through the cloth at the next stitch.

The feed mechanism is shown at Figs. 1, 3, 4, 5, and 6. Two vertical rocking levers, *f f'*, pivoted to the framing A', have rollers at their lower ends, which, by means of springs, are kept in contact with cams G G' on the shafts H K.

On the upper ends of the levers are pivoted arms F F', which act on the upper face of the cloth, their motion being such that they both move together to feed the cloth along; but while one recedes the other holds the cloth fast to the needle-plate E. To produce this motion the arms F F' have extensions connected by rods *f² f³* to bell-crank levers *f⁴ f⁵*, pivoted to the framing A', and having rollers on their other arms kept in contact with cams I I' by means of a spring, *f⁶*. These cams are so formed that while the feeders F F' are performing their feeding motion the rods *f² f³* are pressed upward by levers *f⁴ f⁵*, so as to press the feeders upon the cloth, while during the backward motion of the feeders their tails are drawn down by the action of the spring *f⁶*, so as to raise them off the cloth. The levers *f⁴ f⁵* are connected by links *f⁷ f⁸* and rod *f⁹* to a treadle, 28, (see Fig. 41,) by means of which they may be depressed, so as to raise the feeders F F' off the needle-plate when it is desired to insert or remove the cloth. The feeder F' has a projection or nose, F³, near the needle-hole, as shown at Fig. 4, and detached at Fig. 16, over which the thread lies as it passes from the one side of the cloth to the other while the shuttle is passing through the loop, and while

the loop is being closed again. The motion of the feeder F' being such that it will travel with the cloth while feeding, the loop of thread will keep on its nose so long as it is being pulled backward and forward by the formation of the stitch, and by being thus kept away from the edge of the seam during this operation friction is greatly reduced, and consequently the machine can work at a much higher speed than with the construction shown in the patent referred to. At the moment when the thread is being fully tightened (by the motion of the shuttle and action of the take-up, as before explained) in finishing the stitch the feeder makes a quick motion backward, so as to cause its nose to slide out of the loop. This will be more clearly understood by reference to Figs. 36 to 48, inclusive. Figs. 36 to 40 show diagrams illustrating the various motions of feed-arms F F' during the feed operation, the arrow X, Fig. 36, indicating the direction of the feed, while the horizontal arrows in Figs. 37 to 40 show the direction of motion of the arm, and the vertical arrows show the pressing and releasing action thereof. Fig. 36 shows the feeders F F' both pressing upon the cloth and remaining stationary while the needle is out of the cloth, and in descending pulling the thread through the cloth. Fig. 37 shows the feeders F F' both pressing upon the cloth and performing their feeding motion. Fig. 38 shows the feeders in their respective positions just after one feeding motion has been performed. While the feeder F remains stationary, pressing upon the cloth, the feeder F' loosens its hold and makes a quick motion backward to take a new hold on the cloth. At this moment the thread is being fully tightened and the stitch finished. Fig. 39 shows the position of the feeders ready for a new stitch. Both feeders press upon the cloth and remain stationary while the needle passes up through the cloth. Fig. 40, the needle D moves downward, carrying the loop of thread through the feeder F', presses upon the cloth, and remains stationary, while now the feeder F becomes loose and makes a quick backward motion, so as to take a new hold on the cloth. Figs. 42 to 48 show diagrammatically the action of the apparatus in forming the stitches, and Figs. 49 to 52 show the character of the stitching produced. In Fig. 42 the shuttle is indicated in three different positions, *a' a² a³*, the hook being shown in its attitude corresponding to the position *a³* of the shuttle. Assuming that stitches have been already formed, and that the needle has brought down through the fabric a loop, which is entered by the point of the shuttle in its position *a³*, the shuttle moves outward to *a'*, the loop being drawn tight by its motion and by the action of the take-up, and at the same time the fabric is fed forward, so that the last stitch-hole is removed from above the needle. The shuttle-thread lying now as indicated at Fig. 43, the hook D, having descended, moves, as indicated by the arrow, under the needle-plate. It then moves sidewise at Fig. 44 and

catches the thread below the fabric. It then retreats, as at Fig. 45, and as the shuttle has moved on meanwhile to the position a^2 the previous stitch is drawn tight, and the drag on the thread by the lever 7 being relieved, a length of thread is drawn out for the next stitch. The hook now rises to its highest position, and also advances, as shown at Figs. 2 and 46, and the needle, rising through the fabric, enters the hollow of the hook, throwing out of it the thread-loop, which is now caught by the barb of the hook, so that the needle enters the loop. This hook now performs a small circular movement round the needle, as indicated by Fig. 47, causing the loop to engage in the eye of the needle which is at this time open. The hook then moves, as indicated by the arrow, Fig. 48, and begins its descent. The needle also descends, drawing the loop which it holds down through the stitch-hole. The needle-eye now opens again and the shuttle enters the loop, which is held by a point of the ring V, where it is cut at the side of the needle. The hook now returns to the position indicated in Fig. 42 and the cycle of operations is repeated, producing a series of overhead stitches, as shown at Figs. 49 to 52, of which Figs. 49 and 50 show the two sides of the stitch, while Fig. 51 shows the loop brought down by the needle and partly tightened after the shuttle has passed through, and Fig. 52 shows the stitch tightened. As the hook D moves under the needle-plate, so as to seize the thread coming from the shuttle, it is necessary that this thread should be pulled downward for the hook to enter the loop. This was effected in the patent referred to by means of the feeder, which was there situated below the needle-plate. In the present arrangement, the feeder being above, a special device is provided for this operation, consisting of a finger, F^4 , Figs. 2 and 3, pivoted at F^5 to the framing, and having an arm, with a roller gearing with the groove of cam K^3 on shaft K, so formed as to pull down the finger and with it the thread at the proper moment. When the hook D requires to seize the thread the finger F^4 is moved down from the position shown in Fig. 2 into that shown in Fig. 53, and consequently draws down the thread, which passes underneath it from the shuttle to the stitch, as shown. The hook having seized the thread, the finger rises to its original position again.

In order to lock the stitches fully at the commencement and end of the seam, an arrangement (shown at Figs. 1 and 6) is employed whereby the feed motion is reduced at those times, so as to cause a number of short stitches to be made. For this purpose a bar, 22, sliding in guides on the top of the table, is connected by a bell-crank lever, 23, to the rod of a treadle, by which it can be drawn back against the action of a spring, (not shown,) so as to bring a projection, 26, on its end against the swinging center of feeder F, so as to limit to some extent its feed motion. The bar 22 has a second projection, 27, between two adjust-

ble stops, 24 25, of which the former limits the before-mentioned backward motion of the bar, so as to regulate the shortening of the stitches, while the latter prevents the bar being advanced beyond a certain point by its spring when released by the treadle, and in thus also limiting, by means of projection of 26, the forward motion of lever f and feeder F, it serves to regulate the length of the stitches while sewing.

Having thus described the nature of my invention and in what manner the same is to be performed, I claim in respect of overhead sewing-machines of the kind herein referred to—

1. In the shuttle Y, the combination of the oblong thread-box 2, with cover 3, spring nipping-lever 7, and flanges 16 17, through which the thread passes, substantially as and for the purposes described.

2. The combination of the rotary shuttle Y, the lever 7, pivoted to said shuttle, a spring acting on the lever to normally hold it in contact with a portion of the thread outside the shuttle-cavity, a finger, S, and means for operating the finger to cause the lever to release its nip on the thread, substantially as described.

3. In combination with the shuttle Y, the regulating-hook Z' , carried by arm Q and operated by segment 20, arm 21, cam Q^2 , and lever Z, substantially as and for the purposes herein set forth.

4. The combination of the cam-path Q^3 , the piece Q^3 , the arm Q^4 , the regulating-spring Q^5 , with the screw Q^6 , the arm Q, the hook Z' , segment 20, arm 21, and lever Z, substantially as described.

5. In combination with the hook D, the bar D' , carrier m , with pivot m^2 , and bar n , with arm n^2 , gearing with cam K^2 , constituting a device for imparting to the hook D its compound movement, substantially as herein described.

6. The combination of the needle L, lever-arm C, and cam K' with the needle-slide L' , mounted on lever-arm C^2 and actuated by a cam, K^4 , substantially as herein described.

7. The feeder-arms F F' , mounted on rocking levers $f f'$, actuated by cams G G' , in combination with levers $f^4 f^5$, actuated by cams I I' , constituting the feed mechanism for the cloth, substantially as herein described.

8. In combination with the feeder-arms F F' , rods $f^2 f^3$, and levers $f^4 f^5$, the links $f^7 f^8$ and rod f^9 , operated by a treadle for raising the feeding-arms off the cloth, substantially as herein described.

9. In combination with the feeder-arm F' , the nose F^3 , operating as herein described, for keeping the thread off the edge of the seam while the stitch is being made.

10. In combination with the shuttle Y, needle L, and hook D, the finger F^4 and operating-cam K^3 for drawing down the thread for the hook to enter, substantially as described.

11. In combination with the feeder-arm F and lever f , the sliding bar 22, with projection 26 for limiting the amount of feed motion.

12. In combination with the sliding bar 22 and its projection 26, the projection 27 and adjustable stops 24 25 for regulating the length of stitch, as herein described.

5 13. The combination of the two cam-shafts H K with their cams K' K² K³ K⁴ K⁵ K⁶, G G' I I', driven at the same speed through gearing K⁷ K⁸ K⁹ for imparting the various motions to the needle L, needle-slide L', hook D, feeders F F', and finger F⁴, substantially as
10 herein described.

In testimony whereof I have signed my name to this specification, in the presence of two subscribing witnesses, this 29th day of January, A. D. 1881.

LOUIS BOLLMANN.

Witnesses:

WILLIAM HÜNING,

V. S. TINGLEY.